

R133
User's Manual

IMPORTANT SAFETY INFORMATION



The lightning flash with arrowhead, within an equilateral triangle, is intended to alert the user to the presence of Uninsulated "dangerous voltage" within the product's Enclosure that may be of sufficient magnitude to constitute a risk of electric shock to persons.



CAUTION: TO PREVENT THE RISK OF ELECTRIC SHOCK, DO NOT REMOVE COVER (OR BACK). NO USER-SERVICEABLE PARTS INSIDE. REFER SERVICING TO QUALIFIED SERVICE PERSONNEL.



The exclamation point within an equilateral triangle is intended to alert the user to the presence of important operating and maintenance (servicing) instructions in the literature accompanying the Appliance.

SAFETY INSTRUCTIONS

- Read these instructions.
- Keep these instructions.
- Heed all warnings.
- Follow all instructions.
- Install in accordance with the manufacturer's Instructions.
- Do not use the speakers near water, and do not immerse them in any liquid or pour any liquid on them.
- Do not block the openings in the speaker cabinets, never push objects into speaker vents or slots because of fire or electric shock hazards, and provide sufficient space around the speakers for proper ventilation.
- The apparatus shall not be exposed to dripping or splashing and that no objects filled with liquids, such as vases, shall be placed on the apparatus.
- Do not install near any heat sources such as radiators, heat registers, stoves, or other apparatus (including amplifiers) that produce heat.
- Do not defeat the safety purpose of the polarized plug.
- A polarized plug has two blades with one wider than the other. The wide blade is provided for your safety. If the provided plug does not fit into your outlet, consult an electrician for replacement of the obsolete outlet.
- Protect the power cord from being walked on or pinched particularly at plugs, convenience receptacles, and the point where they exit from the apparatus.
- For added protection during lightning storms, unplug the speakers from the electrical outlet and turn off the computer.
- Unplug this apparatus when unused for long periods of time.
- Water and moisture ---- Do not use the speakers near water, and do not immerse them in any liquid or pour any liquid on them.
- Heat---- Place the speakers away from all heat sources.
- Ventilation ---- Do not block the openings in the speaker cabinets, never push objects into speaker vents or slots because of fire or electric shock hazards, and provide sufficient space around the speakers for proper ventilation.
- Location ---- Place the speakers in a stable location so they will not fall causing damage to the speakers or bodily harm.
- Cleaning ---- Unplug the speakers from the computer and from the electrical outlet before cleaning them with a damp cloth.
- Lightning ---- For added protection during lightning storms, unplug the speakers from the electrical outlet and turn off the computer.
- Servicing is required when the apparatus has been damaged in any way, such as power-supply cord or plug is damaged, liquid has been spilled or objects have fallen into the apparatus, the apparatus has been exposed to rain or moisture, does not operate normally, or has been dropped. Refer all servicing to qualified service personnel.
- Please adjust the audio to proper volume to avoid damaging your health and the system.

WARNING:
**TO REDUCE THE RISK OF ELECTRIC SHOCK,
DO NOT EXPOSE THIS APPARATUS TO RAIN
OR MOISTURE.**

One Year Limited Warranty

Edifier warrants to the end user that all of its computer speaker systems are free from defects in material and workmanship in the course of normal and reasonable use for a term of one year from the date of purchase.

This warranty is the exclusive and only warranty in effect relative to Edifier multimedia speaker systems and any other warranties, either expressed or implied, are invalid. Neither Edifier nor any authorized Edifier reseller is responsible for any incidental damages incurred in the use of the speakers. (This limitation of incidental or consequential damage is not applicable where prohibited.)

Edifier obligation under this warranty does not apply to any defect, malfunction or failure as a result of misuse, abuse, improper installation, use with faulty or improper equipment or the use of the speaker systems with any equipment for which they were not intended.

The terms of this warranty apply only to speaker systems when such speakers are returned to the respective authorized Edifier reseller where they were purchased.

Under the terms of this warranty the original consumer purchaser has certain legal rights and may have other rights which vary worldwide.

Copyright 2004

All Rights Reserved.

Manual Edition 1.0, Aug 2004

Printed in CHINA

Congratulations on your Edifier Purchase !

Thank you for purchasing Edifier R133 Multimedia speaker system. Your Edifier system has been designed to deliver crisp, powerful sound in the computer environment and to maximize the 3D audio capabilities of today's games, movies, and multimedia applications. Please keep this user's manual safely for future reference.

Notice

Edifier and Edifier logo are owned by [Edifier Enterprises Canada Inc.](#) and may be registered. And other brand names and trademarks are the property of their owners. Edifier assumes no responsibility for any errors that may appear in this manual. Information contained herein is subject to change without notice.

 Introduction:

- * Completely MDF wooden case.
- * 4" Long-throw subwoofer driver.
- * 3" full range satellite speaker.
- * Power indicate.
- * Bass and volume controllers.
- * Magnetically shield speakers.

 Open the packing

Please check the speaker Model number marked on the packing carton. Please contact the seller as soon as possible if you find the speaker is the incorrect model or has sustained shipping damage.

* R133 packing list:

- 1 x Sub Woofer
- 2 x satellite Speakers(with cord)
- 1 x User's Manual

* Overview

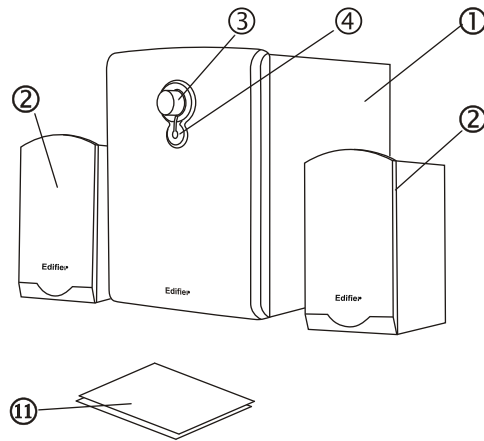

 Introduction of back panel

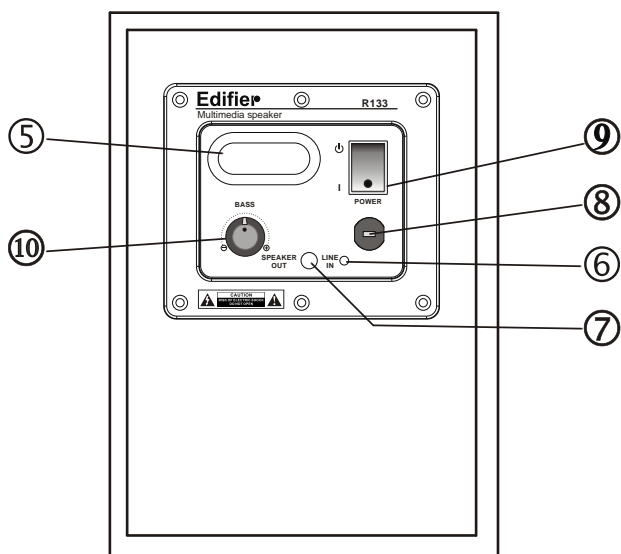

- 1、 Sub Woofer
- 2、 Satellite Speakers (left and right)
- 3、 Volume Control
- 4、 Power Indicator
- 5、 Inverse-phase hole
- 6、 Line in Connector
- 7、 Satellite Speakers Connector
- 8、 Power Cord
- 9、 Power Switch
- 10、 Super Bass Control
- 11、 User's Manual



CONNECTING

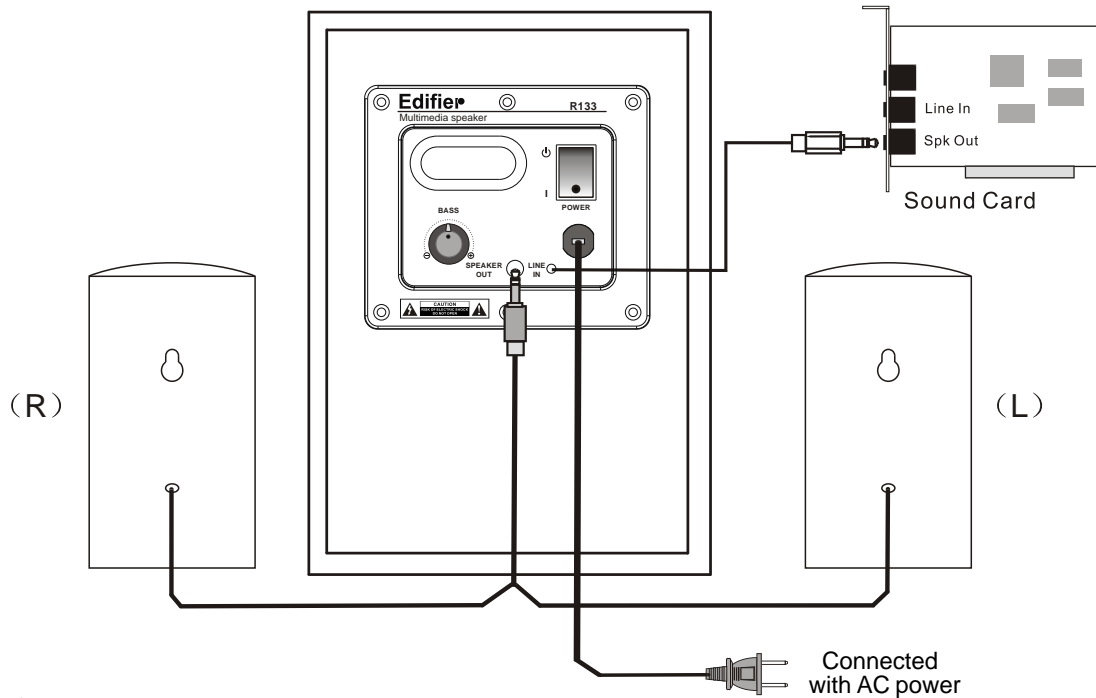

Operating

1、Connecting

Connect the 3.5 Stereo Earphone Plug of the satellite speakers to the output port on the back panel of the Subwoofer.

2、Connecting the Audio device

Connect the 3.5 Stereo Earphone Plug on the subwoofer rear panel to the Audio Device (Such as the computer Sound Card, LINE-OUT, SPK-OUT).

3、Playing the audio device

Plug the AC power plug into the wall outlet and turn on the power switch. Now your speaker system is ready for use. Adjust the volume control, then you can enjoy the music.



SPECIFICATIONS:

Total Power Output :	RMS 2W x 2 + 6W
Input Impedance:	10K Ohm
Input Sensitive:	400 mV
Bass Unit:	4" Aluminum voicecoil, 6 Ohm
Tweeter Unit:	3" Paper voicecoil, 4 Ohm
Frequency Response:	48 Hz ~ 20 KHz
Dimension(Subwoofer):	151(W) x 223(H) x 245(D)mm
Dimension(Satellite):	86(W) x 162(H) x 121(D)mm
Gross Weight:	About 4.1 Kg

Edifier